



# WCTD 2025 ONLINE SEEDER WORKOUT

SCORES DUE BY 8PM, FRIDAY 24 OCTOBER

## EVENT 1

For time:

60 double unders (each)  
20 synchro dumbbell front squats (2x22.5kg/2x15kg)  
15 x 10m shuttle runs (each)  
20 synchro devil's press (2x22.5kg/2x15kg)  
45m handstand walk (split anyhow)

**TIME CAP: 12 minutes**

## Workout Variations

### SCALED:

100 single unders (each)  
20 synchro dumbbell front squats (2x15kg/2x10kg)  
15 x 10m shuttle runs  
20 synchro devil's press (2x15kg/2x10kg)  
45m partner wheelbarrows

## WORKOUT FLOW

- Both partners begin with their back facing the camera.
- At go, partner 1 will perform 60 double unders/100 single skips in the first block. Once complete, they'll tag in partner 2 who will perform 60 double unders/100 single skips in the second block.
- After 120 skipping reps are complete, both athletes will pick up their dumbbells and perform 20 synchro squats, facing each other.
- Once complete, one athlete will begin their set of shuttle runs while the other rests. After partner one has completed 15 x 10m lengths, they'll tag in partner 2 who will then complete 15 x 10m shuttles. (1 rep = 5m down, 5m up)
- Once both sets of shuttles are complete, athletes will move back to the dumbbells and perform 20 synchro devil's press, facing each other.
- A tie-break time will be taken after the last rep of devils press has been completed.
- Finally, once the Devils press are complete, one or both athletes must complete 45m of handstand walks/partner wheelbarrows (split any how), in minimum increments of 2.5m.



# WCTD 2025 ONLINE SEEDER WORKOUT

SCORES DUE BY 8PM, FRIDAY 24 OCTOBER

## FLOOR PLAN

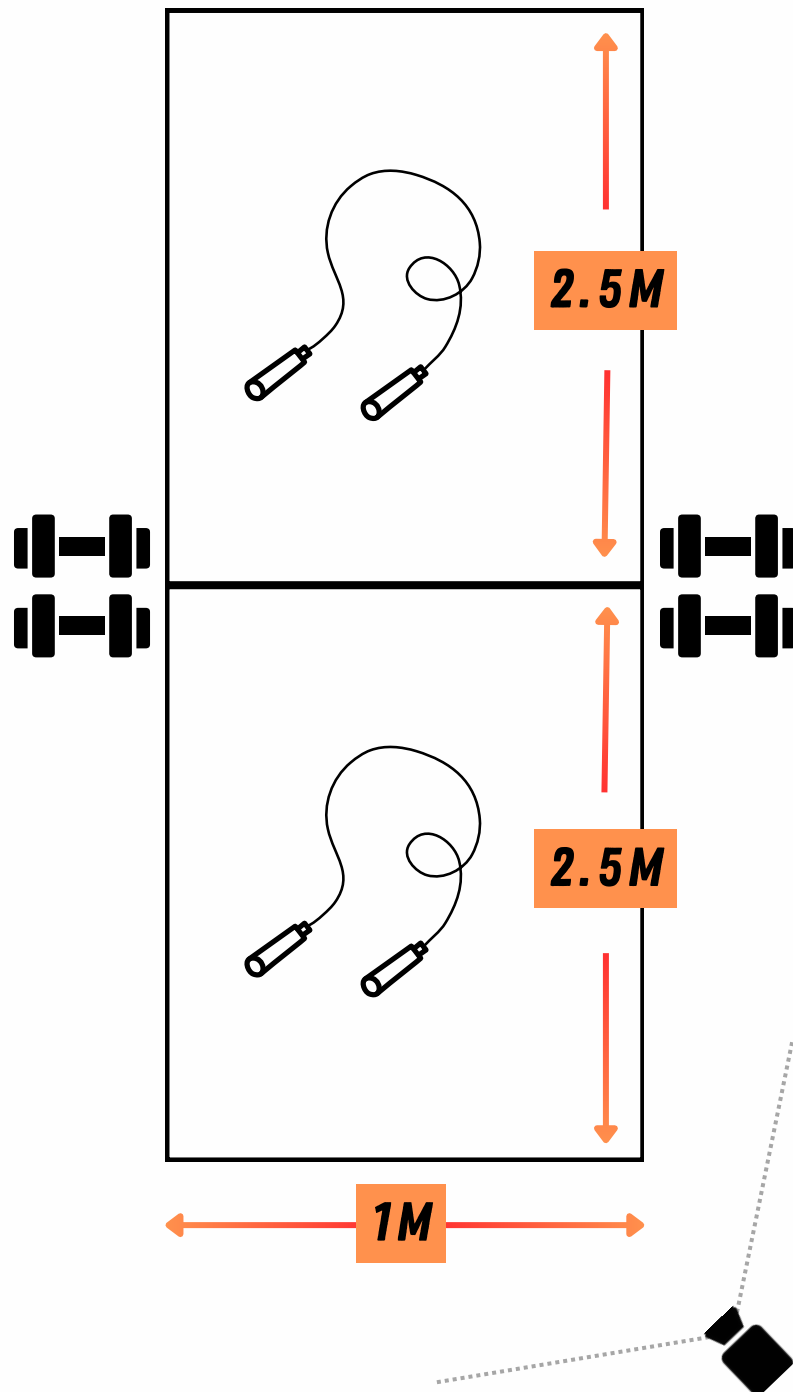

### FLOOR SET-UP:

- Teams must set up a taped block measuring 5m long and 1m wide, with a halfway line marked at 2.5m.
- Skipping ropes must be positioned in each 2.5m block.
- The dumbbells must be set up on either end of the 1m line at the 2.5m halfway mark, facing each other.
- Teams must have a clock visible in frame at all times OR use a recording app such as Wodproof or Wetime.
- Both athletes and the judge must remain in the frame for the entire duration of the workout.
- Any chalk, water or other workout essentials must be in the video frame before the workout begins. Leaving the screen at any point will result in an invalid video.

### Videos will immediately be considered invalid with any of the following issues, with no exceptions:

- The floor layout differs in ANY way from the prescribed setup
- No judge is present
- No timer visible
- Correct weights/measurements are not shown prior to the workout
- Athletes perform any movement in the wrong position
- An athlete or judge moves out of the frame at any point.
- Camera is incorrectly positioned or quality is unclear in a way that makes movement standards difficult to judge.



# WCTD 2025 ONLINE SEEDER WORKOUT

SCORES DUE BY 8PM, FRIDAY 24 OCTOBER

## MOVEMENT STANDARDS

### DOUBLE UNDERS

- The rope must pass under the athlete's feet twice between each jump.
- Each athlete must complete 60 repetitions before tagging out or moving on to the next station.
- For single under reps, the rope must pass under the feet once for every jump.

### SYNCHRO DUMBBELL FRONT SQUATS

- The synchronization of the dumbbell front squat is counted both at the bottom and top of the rep.
- Both athletes' hip crease must clearly pass below the horizontal line of the knees at the bottom of each rep.
- The rep is only awarded when both athletes show full extension of the hips and knees at the top of each rep.
- One athlete may wait in the bottom of the squat for their partner should they move down faster.
- The dumbbell must be in a front rack position. Athletes' hands must be wrapped around the dumbbell handle with one head of the dumbbell clearly in contact with the top of the shoulder at all times.
- The dumbbells can be placed horizontally on the shoulder, but they may not touch or rest behind the neck.



# WCTD 2025 ONLINE SEEDER WORKOUT

SCORES DUE BY 8PM, FRIDAY 24 OCTOBER

## MOVEMENT STANDARDS

### SHUTTLE RUNS:

- Athletes will use the 5m length of the taped box for their shuttle runs.
- Both feet must start behind the furthest line from the camera on the first run.
- At the turnaround point, both feet and one hand must touch the ground clearly behind the line on each end of the 5m lane.
- Each athlete must complete all 15 lengths (1 rep = 5m down and 5m up) before switching out with their partner.

### SYNCHRO DEVILS PRESS:

- The synchronisation of the devils press is counted both at the bottom and top of the rep.
- The rep is only awarded when both athletes show full extension of the hips, knees, shoulders and elbows, with the dumbbells overhead, at the top of each rep.
- Both athletes must have their chests touching the ground between the dumbbells at the same time at the bottom of the rep
- Both athletes must have the dumbbells in a locked out overhead position at the same time.
- The dumbbells must go from ground to overhead in one movement.
- The dumbbells may not touch the shoulders on the way over head.



# WCTD 2025 ONLINE SEEDER WORKOUT

SCORES DUE BY 8PM, FRIDAY 24 OCTOBER

## MOVEMENT STANDARDS

### HANDSTAND WALK:

- Athletes must kick up with both hands clearly behind the line.
- Handstand walks are awarded in 2.5m increments.
- Athletes may come down after each 2.5m line as long as both hands have clearly passed the line.
- Only one athlete will handstand walk at a time. Should partners choose to switch out at any point, the following partner must continue the handstand walk from where the previous one left off.

### PARTNER WHEELBARROW:

- Athletes must kick up with both hands clearly behind the line.
- The carrying partner may be anywhere between the walking partners knees and feet. Reps done holding the walking partner anywhere above the knees will not be counted.
- Wheelbarrow walks are awarded in 2.5m increments.
- Athletes may come down after each 2.5m line as long as both hands have clearly passed the line.
- Should partners choose to switch out at any point, the following partner must continue the wheelbarrow walk from where the previous one left off.

